

Model D 363

S-Type Load Cell

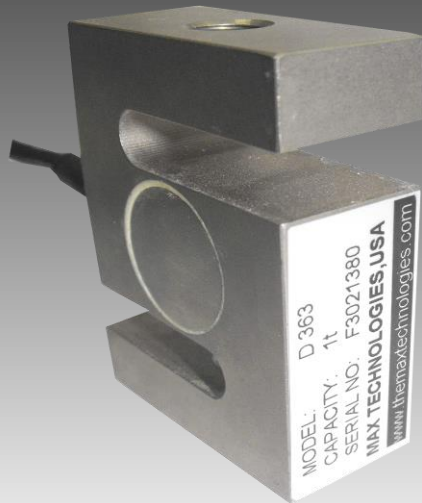

FEATURES

- **Rated Capacities (lb):**
10, 100, 200, 550, 1000, 2000, 4500,
5500, 11,000, 22,000, 45000
- **Rated Capacities (kg):**
05, 50, 100, 250, 500, 1000, 2000, 2500,
5000, 10,000, 20,000
- Alloy Steel
- IP 67
- Tension and Compression Type

APPLICATIONS

- Electromechanical Scales, Crane Scales,
Tank, Bin and Hopper Weighing

TECHNICAL DATA

Rated Capacities (lb):	10, 100, 200, 550, 1000, 2000, 4500, 5500, 11,000, 22,000, 45,000
Rated Capacities (kg):	05, 50, 100, 250, 500, 1000, 2000, 2500, 5000, 11,000, 20,000
Rated Output	3.0 mV/V
Non-linearity	± 0.02%FS
Hysteresis	± 0.02%FS
Non-Repeatability	± 0.01 % FS
Creep (30minutes)	±0.02%FS
Zero Balance	± 1.00%FS
Temperature effect on zero	± 0.02%FS/10C°
Temperature effect on output	± 0.02%FS/10C°
Input Resistance Ω	385 ± 10
Output Resistance Ω	350 ± 3
Insulation Resistance	≥5000 M Ω
Excitation Voltage	10V(DC/AC)
Compensated Temperature Range	-10C°~+40C°
Operating Temperature Range	-20C°~+60C°
Safe Overload	120%FS
Cable Length	16.4ft / 5M

The technical data given here serve only as a product description and must not be interpreted as guaranteed characteristics in the legal sense.

Model D 363

OUTLINE DIMENSIONS:

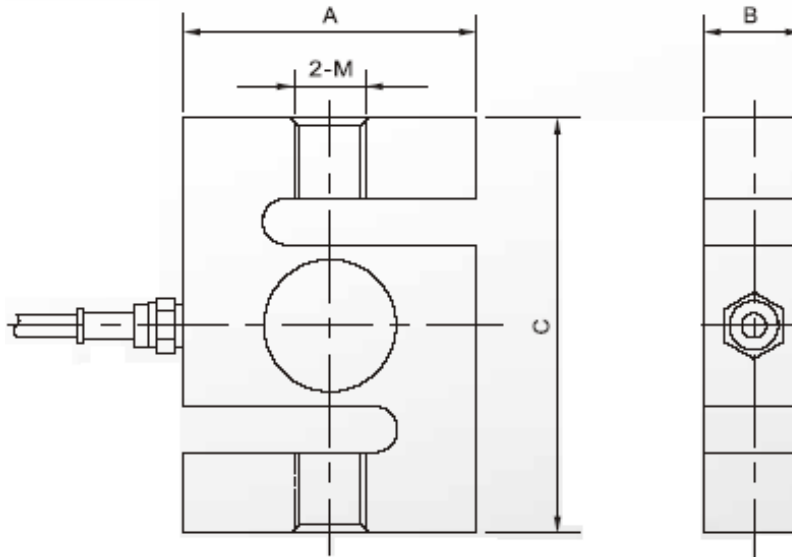

DIMENSIONS:

Capacity lb/ches	A	B	C	Thread
10-100	2.01	0.51	2.52	2-M
200-1000	2.01	0.75	3.00	M0.47X0.06
2000-4500	2.13	1.0	3.00	M0.47X0.06
5500-11000	3.00	1.0	4.26	M0.71X0.05
15,000	3.94	1.26	5.52	M0.94X0.07
22,000	4.97	1.97	7.02	M1.18X0.07
45,000	5.52	2.36	7.42	M1.54X0.07
Capacity kg/mm				Thread
5-50	51.0	13.0	64.0	M8X1.25
100-500	51.0	19.1	76.0	M12X1.75
1000-2000	54.0	25.4	76.0	M12X1.75
2500-5000	76.0	25.4	108.0	M18X1.5
7500	100.0	32.0	140.0	M24X2
10,000	126.0	50.0	178.0	M30X2
20,000	140.0	60.0	188.0	M39X2

WIRING

Function	Colors
+ Excitation	Red
- Excitation	Black
+ Signal	Green
- Signal	White

Correct Mounting of Load Cells Is Essential To Ensure Optimum Performance.

3193 N, Drinkwater Blvd, P.O.Box 32662, Scottsdale, AZ 85251, U.S.A

Phone: # 480-240-1299

Fax: # 480-240-1300

Email: Info@themaxtechnologies.com

Max Technologies reserves the right make changes to the technology, features, specification and design of the equipment without notice.