

# Model D 430

Single Ended Beam Load Cell

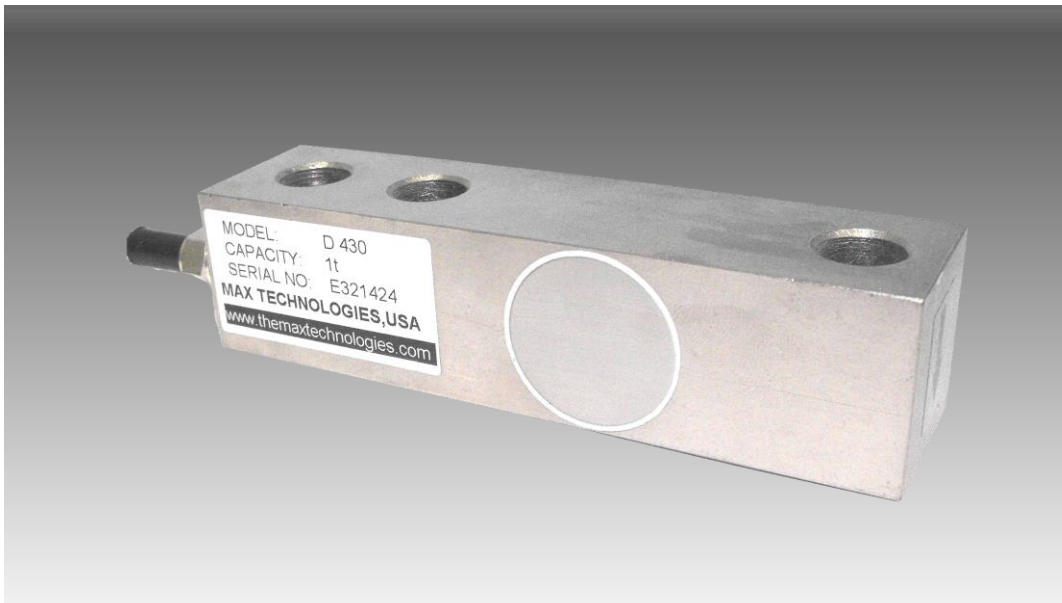

## FEATURES

- **Rated Capacities (lb):**  
1000, 2000, 4500, 5500, 10,000, 15,000, 20,000
- **Rated Capacities (kg):**  
500, 1000, 2000, 2500, 5000, 7500, 10000
- Alloy Steel
- Welded Seal Construction IP67
- Single Ended Beam Type

## APPLICATIONS

- Suitable for Industrial Platform Scales, Tank Bin and Hopper Weighing.

## TECHNICAL DATA

<b>Rated Capacities (lb):</b>	1000, 2000, 4500, 5500, 10,000, 15,000, 20,000
<b>Rated Capacities (kg):</b>	500, 1000, 2000, 2500, 5000, 7500, 10000
Rated Output	3.00 mV/V
Combined Error	± 0.02 % FS
Non-linearity	± 0.02 % FS
Hysteresis	± 0.02 % FS
Non-Repeatability	± 0.02 % FS
Creep (30minutes)	± 0.02 % FS
Zero Balance	± 1.00 % FS
Temperature effect on zero	± 0.02 % FS/10°C
Temperature effect on output	± 0.02 % FS/10°C
Input Resistance $\Omega$	385 $\Omega$ ± 10 $\Omega$
Output Resistance $\Omega$	350 $\Omega$ ± 3 $\Omega$
Insulation Resistance $\Omega$	≥5000M $\Omega$
Excitation Voltage	10V(DC/AC)
Compensated Temperature Range	-10°C ~+ 40 °C
Operating Temperature Range	-20~+ 60 °C
Safe Overload	120% FS

The technical data given here serve only as a product description and must not be interpreted as guaranteed characteristics in the legal sense.

# Model D 430

## OUTLINE DIMENSIONS:

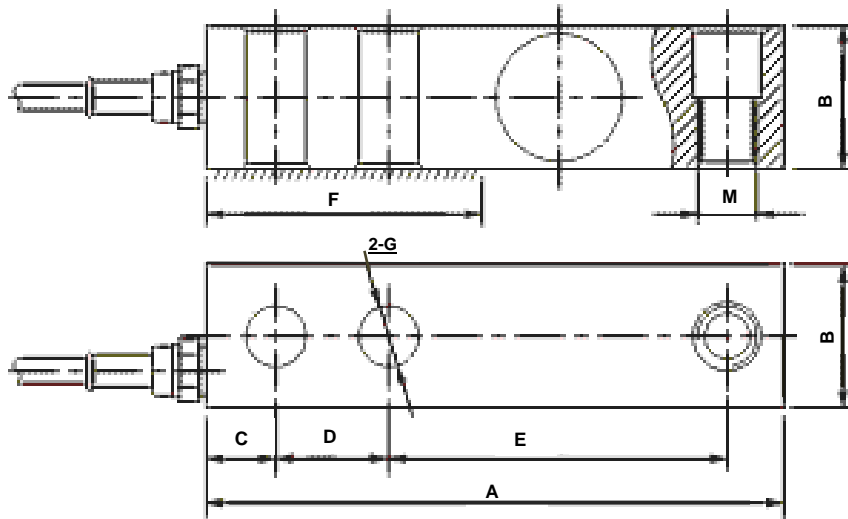

## DIMENSIONS

Capacity	A	B	C	D	E	F	G	Thread
<b>lb/inches</b>								
1000-4500	5.13	1.26	0.61	1.00	3.00	2.25	0.53	M0.47X0.06
5500-10,000	6.77	1.50	0.75	1.50	3.76	3.00	0.78	M0.71X0.05
15000-20,000	8.78	2.00	1.00	2.00	4.88	4.02	1.06	M0.94X0.07
<b>kg/mm</b>								
500-2000	130.0	32.0	15.7	25.4	76.2	57.0	13.5	M12X1.75
2500-5000	171.5	38.0	19.1	38.1	95.3	76.0	20.0	M18X1.5
7500-10,000	222.5	50.8	25.4	50.8	123.8	102.0	27.0	M24X2

## WIRING

Function	Colors
+ Excitation	Red
- Excitation	Black
+ Signal	Green
- Signal	White
Shield	Braid

Correct Mounting of Load Cells Is Essential To Ensure Optimum Performance.

3193 N, Drinkwater Blvd, P.O.Box 32662, Scottsdale, AZ 85251, U.S.A

Phone: # 480-240-1299

Fax: # 480-240-1300

Email: [Info@themaxtechnologies.com](mailto:Info@themaxtechnologies.com)

Max Technologies reserves the right to make changes to the technology, features, specification and design of the equipment without notice.